



Manjushree Technopack Limited
Corporate Office
2nd Floor, MBH Tech Park, 46,47,
Hosur Road, Electronic City Phase II,
Bangalore 560 100, Karnataka INDIA
T : 91 80 4343 6200
E : info@manjushreeindia.com
www.manjushreeindia.com



Preforms Division - Bidadi

Plot No. 71 &72, Sector 2, Phase 2
Bidadi Industrial Area,
Bangalore 562 109, Karnataka
INDIA



Preforms Division - Pantnagar

Plot No. 23, Sector 2,
Integrated Industrial Area,
Pantnagar 263 145, Uttaranchal
INDIA

Preforms Division - Guwahati

Village : Nizsindurighopa,
Chowkigate, Changsari
Guwahati 781 101 Assam
INDIA

Preforms Division - Silvassa

MTL New Initiatives Pvt. Ltd.,
Haveli Estate, Building - A&B,
Survey No 121/26 Village Amil, **Silvassa**,
Dadra & Nagar Haveli - 396230
101 Assam
INDIA



Preforms Division - Vizag (Upcoming)

Plot No.1 ,Block-G, Survey No.38,46-49
Part, Industrial Park, Gajuwaka,
Visakhapatnam, Anakapalli,
Andhra Pradesh, 530046
INDIA



MEForms
For peace of mind

Complete beverage packaging solutions

Manjushree Technopack Limited
INDIA



- **Unparalleled quality:** High performance preforms and closures. Largest beverage manufacturers in India rely on us for seamless quality and peace of mind.
- **Large portfolio across segments:** We offer large portfolio of preforms and closures for most necks used in beverage segment. You don't have to look elsewhere for your preform and closures needs when you partner with us.
- **Continuous innovation:** MTL was first to launch large scale commercial capacity of PCO 1881 preforms in India. We are again first to launch large scale capacity of 32mm aseptic and 26/22 preforms in India.
- **Assured supplies:** Warehousing space and season pre-build of up to 20K MT of preforms and closures across plants. Preform or closures shortfall and business loss in season is the last worry for our regular customers - Peace of mind.
- We are South Asia's largest beverage packaging material manufacturer. End to end capability for beverage packaging - preforms, closures, shrink film and jars.
- Capacity of more than 100K MT per annum of PET conversion to preforms and more than 6 billion closures.
- We work with all major beverage manufacturers in the country. Largest supplier to both Coca-Cola and Pepsico in India.
- **Country wide presence:** Preform manufacturing capability at Bangalore, Pantnagar, Visakhapatnam, Guwahati and closures manufacturing capability at Jalgaon.
- **State-of-the-art of platform:** Largest Husky platform in India and from other reputed OEM'S. Largest number of SACMI machines for closurs under one roof.
- We also offer state-of-the-art solution for bulk water manufacturing: 5 ltr, 10 ltr and 20ltr jars, preforms, caps and handles.
- State-of-the-art Reifenhauer platform for shrink film.
- Our 5000 + customer and stock products serve customers across multiple segments.
- We successfully completed our management transition in 2019 and are now governed by professional board and management team.

Manufacturing Footprint

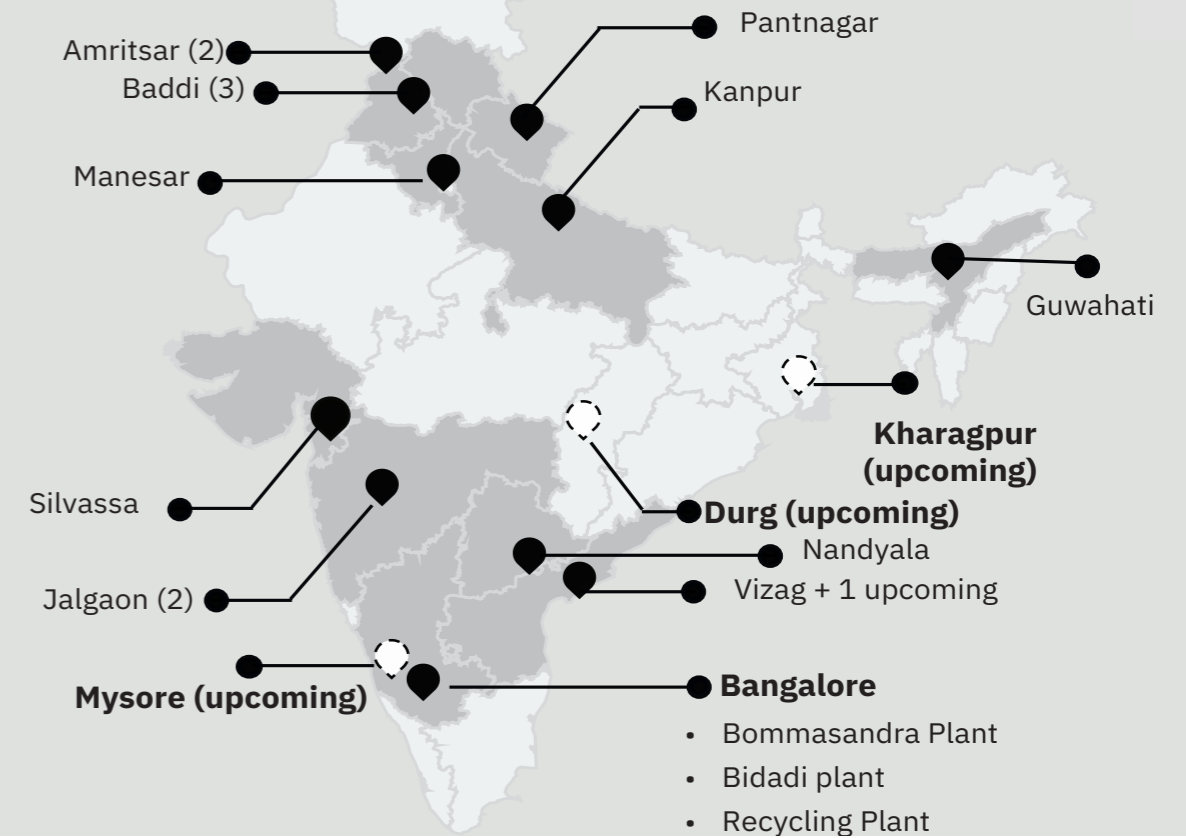

MTL Story

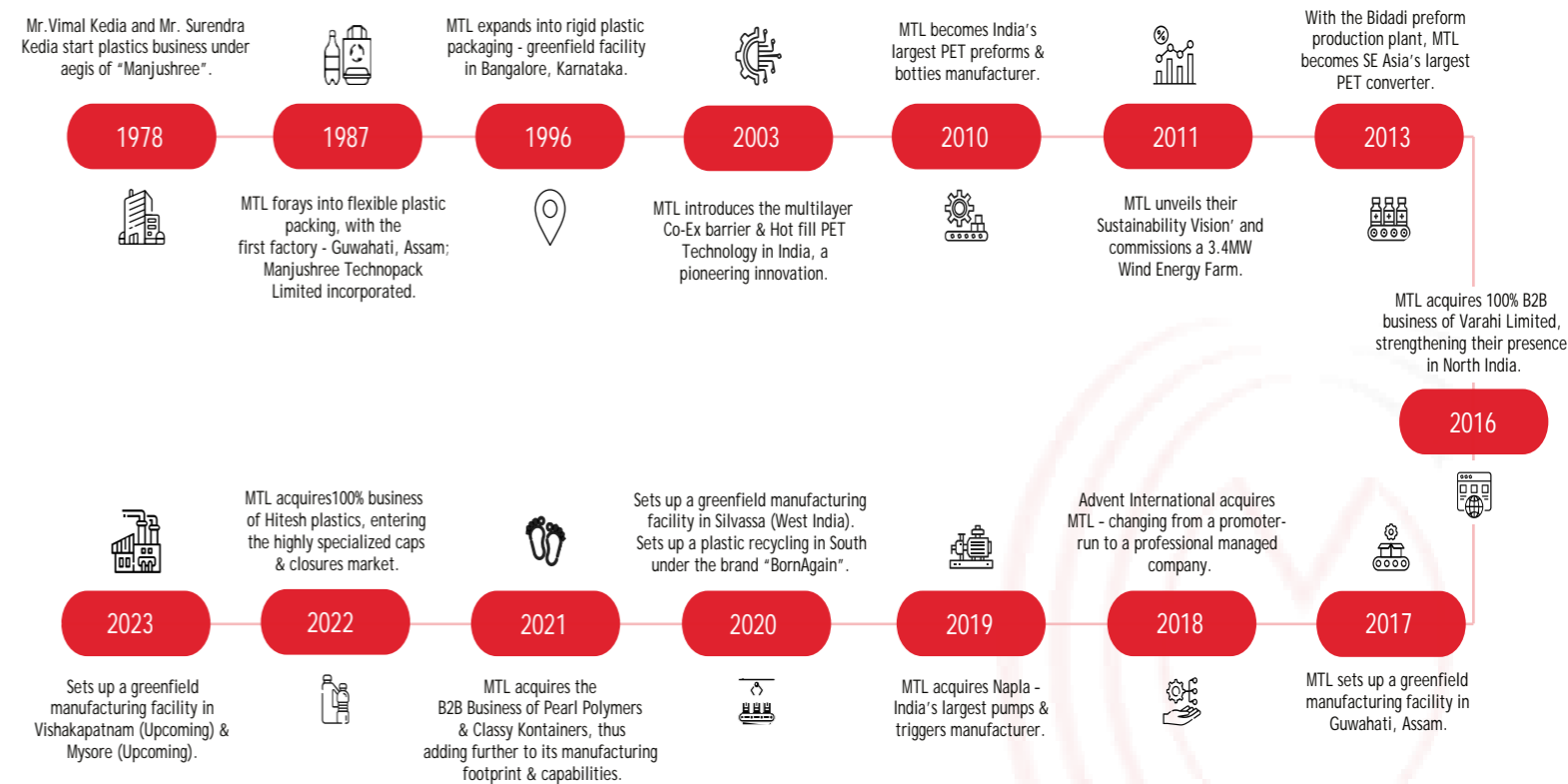

Leveraging our wide product portfolio across pack type and fill volume



Sparkling Beverages

- Widest application offering (150ml - 3000ml)
- HUSKY platform - Highest Quality & Consistency
- All Necks for CSD Application

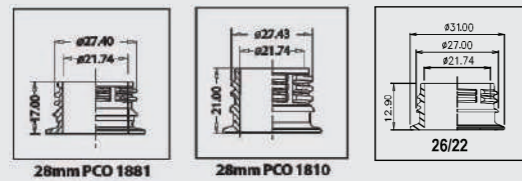

Hot Fill / Juice

- Widest application offering (250ml - 1500ml)
- Offerings on both platforms, TN & PCO1881
- Aseptic 32mm prefoms

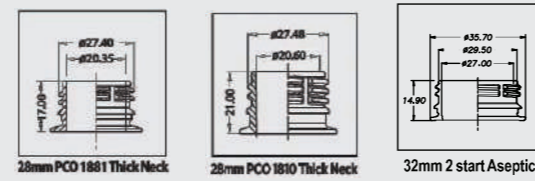

Water

- Widest application offering (200ml - 2000ml)
- HUSKY platform - Highest Quality & Consistency
- All necks for water application

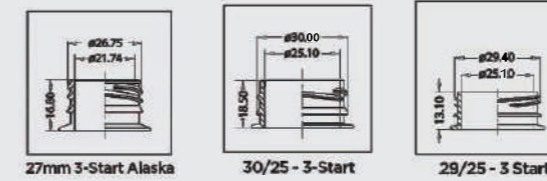

Edible Oil

- Offering on both solutions CTC & NSN neck types
- Application offering from (200ml -1000ml)

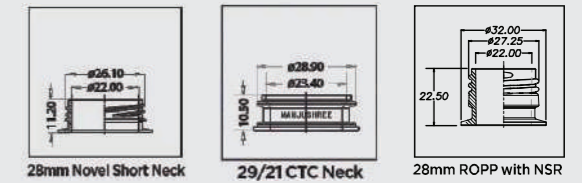

Closures	2.35, 2.5, 2.75		1.8
Volume (ml)	Weight (gm)	Weight (gm)	Weight (gm)
150ml 200ml	9.8		9.9
	10.5		
	11.5		
	12.0		
200ml - 250ml	12.0	15.1	
	13.0	16.5	
300ml	14.7	17.8	13.0**
	15.9		
	16.0		
500ml	18.5	23.5	
	19.5	25.0	
	21.4	25.5	
	22.2	27.0	
600ml	22.2		20.5**
	23.0		
	25.1		
	25.7		
750ml	27.1		
	29.8		
	30.7		
1000ml 1500ml	30.7	36.0	44.0**
	31.9		
	32.5		
	34.7		
	37.7		
	45.5		
2000ml -2500ml	46.7	48.0	
	52.7		
3000ml	56.7		

	2.10, 2.20	2.75	2.4
	Weight (gm)	Weight (gm)	Weight (gm)
			13.6
	18.0	18.5	
	22.4	23.8	
		27.0	
	33.0**		
	45.7	47.0	36.0**

	1.5, 1.35		
	Weight (gm)	Weight (gm)	Weight (gm)
	9.5**		
	10.0		
	10.6		
	12.5	15.3	12.0
	13.5		
	13.6		
	15.6	18.0	
	19.0	20.1	17.15
	19.5	22.0	18.6
	20.0	28.0	26.0
	21.0	31.5	
	22.0		
	32.5	37.2	
	34.0		
	35.6		

	1.0		
	Weight (gm)	Weight (gm)	Weight (gm)
			8.5
	8.0	10.0	
	12.0	13.0	25.0
		14.5	
		15.3	
	18.0	19.5	47.0
	19.0	21.5	
		24.0	

**Soon to be launched

PREFORMS AVAILABLE FROM BIDADI

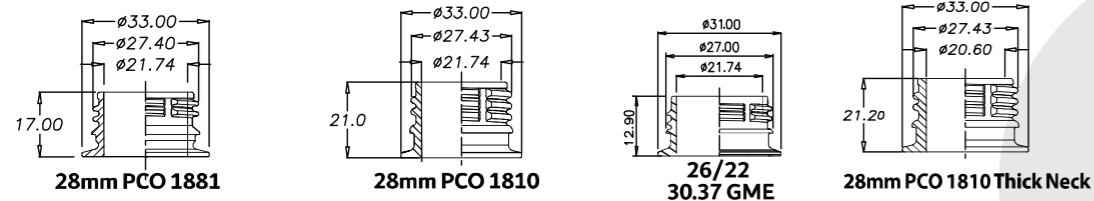

Weight (gm)	Length (mm)
10.50	65.00
11.50	76.00
12.00	76.00
13.00	76.00
14.70	80.30
14.70	81.00
14.70	81.00
15.90	78.00
16.00	80.30
16.00	81.00
16.00	81.00
18.50	94.00
19.50*	94.56
21.40*	94.56
22.20	94.00
22.20	96.50
23.00	96.50
25.70	96.50
25.70	103.2
25.10*	97.00
27.10	96.50
29.81*	107.0
30.70	106.5
31.93*	123.8
32.00	122.0
32.50	123.3
34.70	123.3
37.70	124.5
45.50	144.0
46.70	135.0
52.70	144.0
56.70	144.0

Weight (gm)	Length (mm)
15.10	83.20
16.50	82.50
17.80	82.50
17.50	85.00
23.50	98.00
25.00	95.80
25.50	100.50
27.00	100.50
27.00	107.40
36.00	127.30
39.00	128.50
48.00	139.00

Weight (gm)	Length (mm)
9.90	71.90
9.90	69.00

Weight (gm)	Length (mm)
18.50	84.50
23.80	87.97
27.00	107.40
34.20	114.00**
47.00	139.00

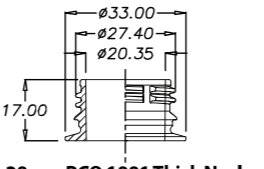

Weight (gm)	Length (mm)
18.00	70.90
22.40	83.77
33.00	110.00
45.70	135.00

PREFORMS FOR HOT FILL FRUIT JUICES



Snap 55 mm - 20Ltr water		Thread 55 mm - 20Ltr water	
Weight (gm)	Length (mm)	Weight (gm)	Length (mm)
675.00	386.00	675.00	376.00

48 mm 3start	
Weight (gm)	Length (mm)
82.00	134.50
200.00	180.00

PREFORMS FOR BULK WATER PACKAGING



Available as preforms or as complete BLOWN JARS, together with closures



PREFORMS FOR CSD, SODA AND WARM FILL JUICE



PREFORMS FOR WATER AND EDIBLE OILS

WIDE MOUTH PREFORMS

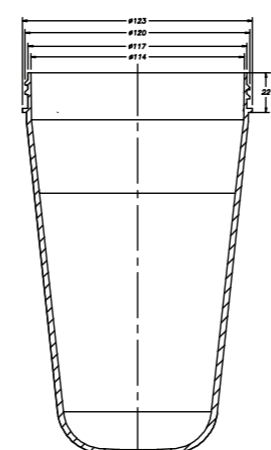

Weight (gm)	Length (mm)
105.0	114.0
110.0	130.0
120.0	130.0
125.0	140.0
126.0	130.0
140.0	140.0
240.0	207.0
260.0	207.0
320.0	207.0

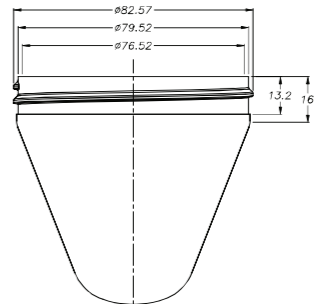

Weight (gm)	Length (mm)
38.00	63.00
50.00	63.00

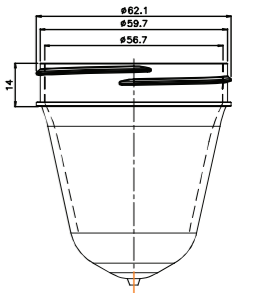

Weight (gm)	Length (mm)
30.00	70.00
34.00	70.00
36.00	70.00

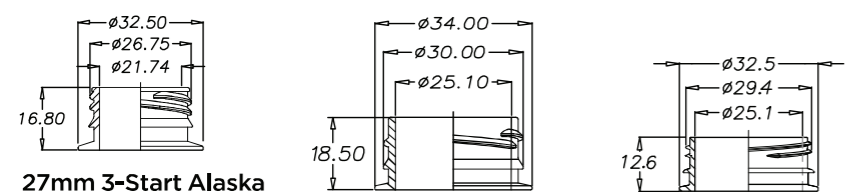

Weight (gm)	Length (mm)
9.30	65.00
10.00	64.80
10.60	66.00
12.50	81.00
12.50	81.00
13.60	81.00
13.50	81.00
13.60-L	84.00
15.60	84.00
19.50	104.0
19.00	100.50
20.00	107.80
21.00	104.0
21.00	100.50
22.00	107.80
32.50	125.00
34.00	125.00
35.60	125.00

Weight (gm)	Length (mm)
15.30	86.00
18.00	86.00
20.10	109.50
22.00	109.50
28.00	110.00
31.50	110.00
37.20	127.90

Weight (gm)	Length (mm)
12.00	80.10
17.15	96.50
18.60	94.36
26.00	104.10
32.00	122.0

Weight (gm)	Length (mm)
12.00	78.00

Weight (gm)	Length (mm)
110.00	195.00

Weight (gm)	Length (mm)
29.00	100.00

Weight (gm)	Length (mm)
14.50	80.50
15.30	80.50

INNOVATION

26/22 Neck Preforms for CSD/ Warmfill

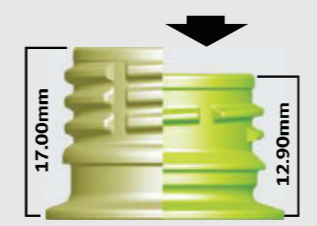

PCO 1881 | PCO 26/22

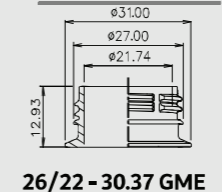
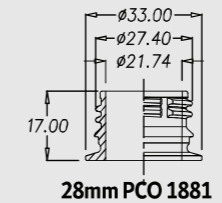

Weight (gm)	Length (mm)
9.20*	69.00
9.90	71.90
10.40*	71.90
11.40*	71.90

*Soon to be launched

The first large scale commercial installation of 26/22 portfolio preforms in India. Plan to scale up for all major packs soon.

Continuing its legacy of innovation and ahead of time investments, Manjushree proudly launches 26/22 preforms in India. These preforms offer 1.50 gm saving in preform weight and 0.8 gm saving in closure weight – total of 2.3 gm

PREFORMS AVAILABLE FROM GUWAHATI

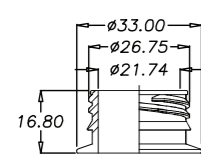

28mm 3-Start Alaska

Weight (gm)	Length (mm)
10.00	64.80

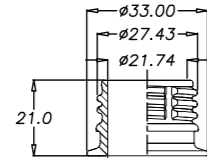

28mm PCO 1810

Weight (gm)	Length (mm)
12.40	80.55
14.60	80.55

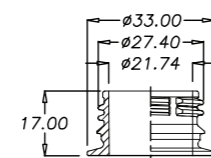

28mm PCO 1881

Weight (gm)	Length (mm)
9.80	66.00
10.30	66.00
10.50	66.00
12.00	76.35
13.00	76.35

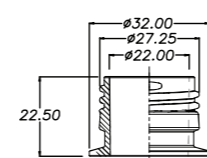

28mm ROPP with NSR

Weight (gm)	Length (mm)
25.00	104.0

PREFORMS AVAILABLE FROM PANTNAGAR

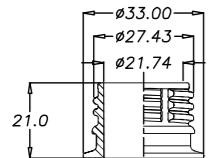

28mm PCO 1810

Weight (gm)	Length (mm)
12.90	72.50
25.00	19.80
49.50	139.0

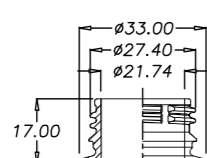

28mm PCO 1881

Weight (gm)	Length (mm)
10.50	68.50
11.20	68.50
12.50	72.50
12.50	81.00
13.40	72.50
13.50	81.00
14.50	81.00
15.17	72.50
23.70	91.80
25.70	96.50
29.80	107.0
30.70	106.5

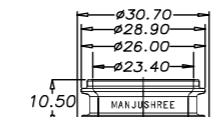

29/21 CTC Neck

Weight (gm)	Length (mm)
10.00	80.50
13.00	83.00
19.50	101.0
21.50	101.0
24.00	101.0

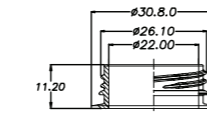

28mm Super Short Neck

Weight (gm)	Length (mm)
8.00	64.00
8.20	64.00
12.00	78.00
18.00	99.50
18.20	99.00
19.00	99.00

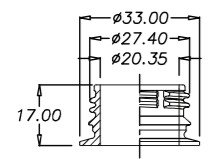

28mm PCO 1881 Thick Neck

Weight (gm)	Length (mm)
18.00	70.90
22.15	83.77

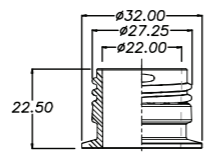

28mm ROPP with NSR

Weight (gm)	Length (mm)
47.00	141.30

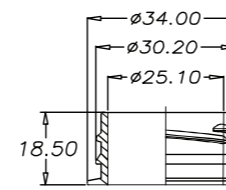

30/25 - 3-Start

Weight (gm)	Length (mm)
22.00	110.0

PREFORMS AVAILABLE FROM VISAKAPATNAM

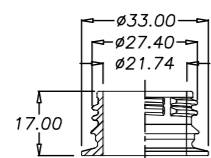

28mm PCO 1881

Weight (gm)	Length (mm)
15.17	72.45
29.80	107.0
52.70	144.0

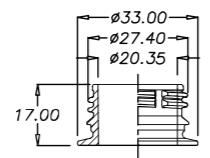

28mm PCO 1881 Thick Neck

Weight (gm)	Length (mm)
18.00	70.90

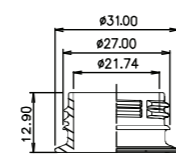

26/22

Weight (gm)	Length (mm)
9.90	69.00
9.20	69.00



PEACE OF MIND

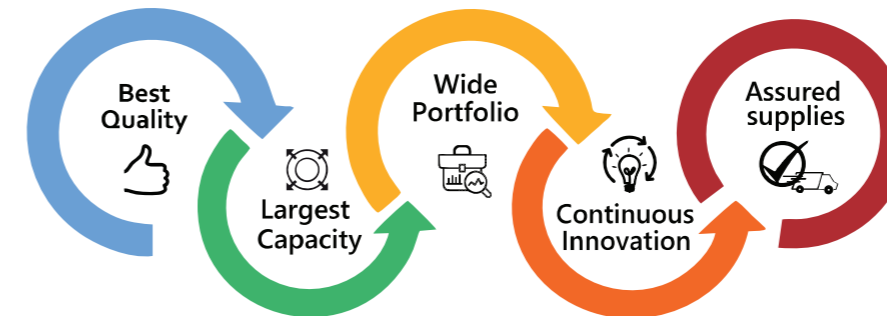

SERVICES FOR MTL CUSTOMERS

- Acetaldehyde test
- Moisture test
- Automatic optical imaging based dimension test
- Top load test for bottles and Jars
- Design support for new packs
- New preform development
- On-site troubleshooting and audit support



INNOVATION

32mm Aseptic / Cold Fill Preforms

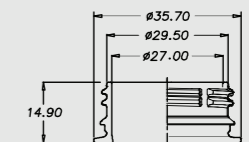

32mm 2 start Neck

Weight (gm)	Length (mm)
13.60	66.30
36.00	102.9**

**Soon to be launched



38mm Neck | 32mm Neck



29% (2.09gm) Total Package Savings !

MTL Proudly announces launch of 32mm neck aseptic preforms. These preforms promise following advantages against 38mm neck :

- Vented slot for better blow-off performance like 38mm 2 Start.
- B-step like 38mm 3 Start neck
- Better drinking experience for small and as well as large pack with optimum bore diameter
- Cetic standard neck GME 30.36 uniform globe standard neck
- Proven performance and successful across markets, OEM and product
- Global brands moving from 38mm to 32mm

Closures for Beverage Industry



WATER

27mm Alaska	26mm NSN	20Ltr
1.5gm 1.35gm	1gm	11gm



CSD

25mm	PCO-1881	PCO-1881	26/22
1.8gm , 1.65gm Single Piece	2.75gm 2 Piece	2.5gm (6 Design) 2.35gm (13 Design)	1.8gm 30.37GME



JUICE

25mm	PCO-1881	PCO-1810	28mm Hot Fill
1.45gm, 1.55gm Single Piece	2.1gm	2.7gm	1810 - 2.75gm 1881 - 2.2gm



ASEPTIC

32mm Aseptic	38mm 2 Start	38mm 3 Start
2.5gm	3.4gm	3.0gm



SAUCE & HONEY

32mm Fliptop with TPE Valve
10.5gm (Big) 4.0gm (Small)



HEALTHCARE

25mm , 20mm Flip Top Caps
3.3gm / 1.9gm

Complementary Products



Reifenhäuser

BLOWN FILM

**SHRINK YOUR WORRIES,
SEAL NEW POSSIBILITIES**

Plastic bottles

Metal cans

Glass packages

Paper composites

Tetra pack cases

Wrapping
up your needs



In a bid to fill in, every step of the supply chain in the packaging eco-system, we have stepped in to offer end-of line packaging solutions too. Introducing our brand new 3-layer Collation Shrink Film line. From Reifenhäuser, Germany. The plant has been specifically customized for the most efficient productions of LD shrink film. This shrink film provides you with an opportunity to reduce your existing paper carton for lesser packaging cost, easy handling and great merchandising appeal. The high performance collation shrink film has been specifically developed, keeping in mind the extreme climatic conditions of India, vagaries of transportation and the need for extended durability.



PEPSICO

HSIL



Bisleri.



* We also have a wide variety of Injection molded closures in a variety of neck options. Please contact for more details.